

HIGH SPEED MULTI-HEAD WEIGHER

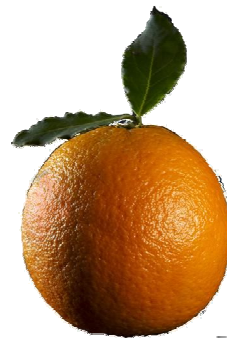

For potatoes, onions, citrus and similar products

- Robustly constructed in stainless steel
- Space saving compact design
- Pack weight programming in seconds
- Fully automatic infeed control
- Automatic taring
- Capable of running with one or more channels disabled
- Count by weight, minimum weight or average weight programmes
- Positive counting with photocells available as an option
- Easy to combine with one or more packaging machines

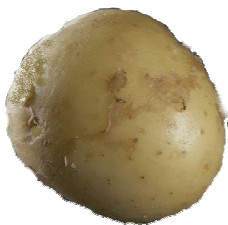
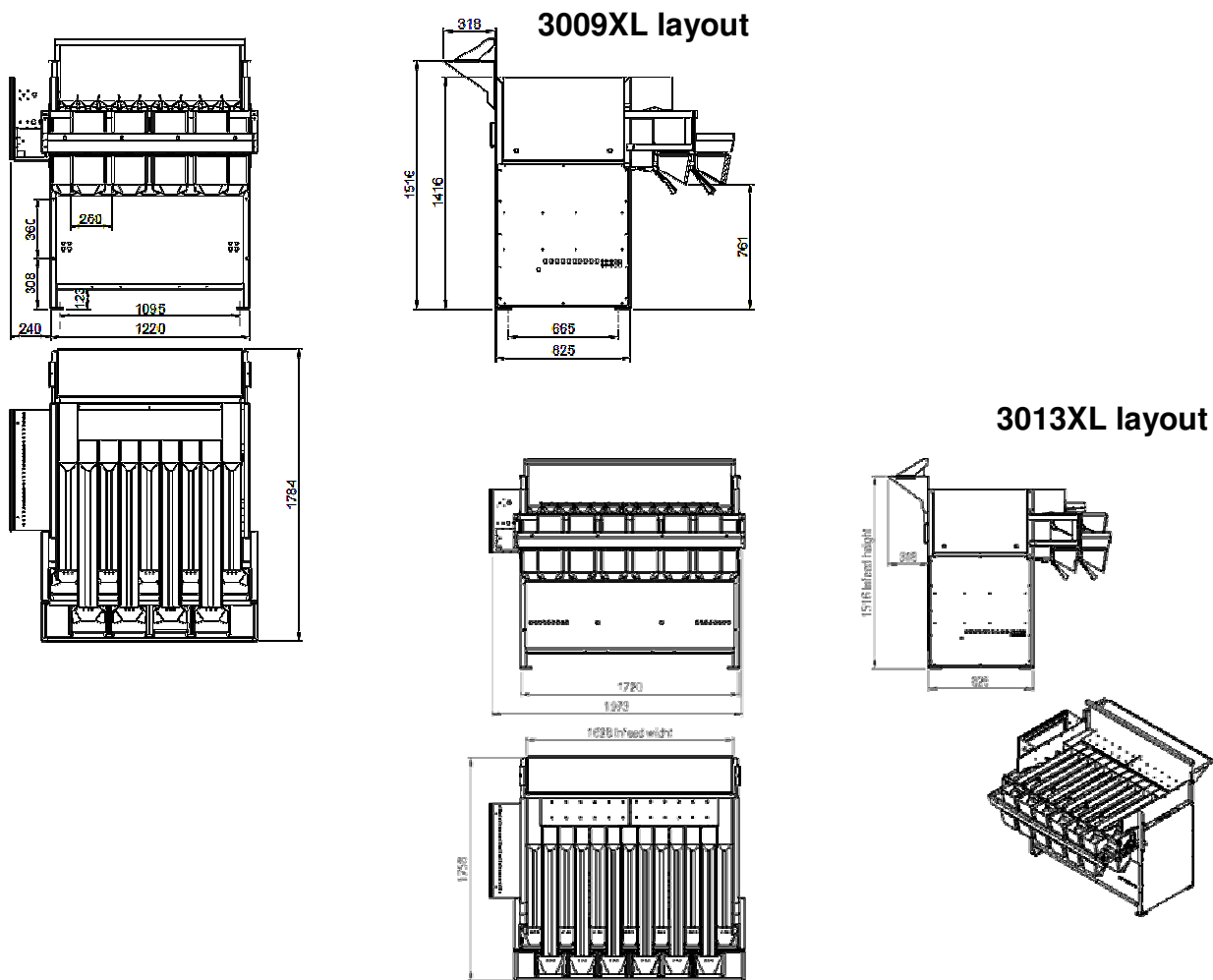

Capacity - 3009XL

Portions per min.	0,5 Kg	1 Kg	2,5 Kg
Onions	45	43	35
Citrus	45	43	35
Potatoes	45	43	35

Technical Data

- Air requirement
- Consumption: 150l
- Electrical requirement
- Connection: 3 x 400 V AC + N + PE
- Consumption 3009XL: 1kW

Capacity - 3013XL

Portions per min.	1 Kg	2 Kg	5 Kg
Potatoes	70	60	50
Onions	70	58	45
Citrus	50	45	-
Oranges	50	45	-